

Predictive Molding of Precision Glass Optics

Shriram Madapusi¹, Nam-Ho Kim²
University of Florida

Yazid Tomhe³
Moore Nanotechnology Systems

Copyright © 2008 SAE International

ABSTRACT

Precision glass molding process is an attractive approach to manufacture small precision optical lenses in large volume over traditional manufacturing techniques because of its advantages such as low cost, fast time to market and being environment friendly. In this paper, we present a physics-based computational tool that predicts the final geometry of the glass element after molding process using the finite element method. Deformations of both glass and molds are considered at three different stages: heating, molding, and cooling. A 2D axisymmetric finite element model is developed to model the glass molding process. The proposed modeling technique is more efficient than the all-in-one modeling technique. The molds are assumed to be rigid, except for thermal expansion, at all time and glass treated as a flexible body during the compression. Details on identifying material parameters, modeling assumptions, and simplifications are discussed. The tool can be used to predict the final shape of the molded optic. This tool eventually can be used to design proper mold geometry that yields the correct shape of the final optical element, thereby eliminating the iterative procedure for designing the molds.

INTRODUCTION

In the recent years, aspherical glass optics is widely chosen because of their superior optical properties, such as lesser aberration and lower birefringence, over plastics and spherical optics. The traditional lens manufacturing process is a multi-step process which requires a series of material removal processes [1, 2]. Although, there have been recent advances in optical fabrication techniques such as magnetorehological finishing and ion beam polishing [3], the complexity of these processes is such that the overall costs are high for medium to high volume production of aspheric optics. Furthermore, the process incurs environmental issues because of the use of grinding fluids and polishing slurries.

A potential low-cost and fast method to produce precision glass optics is a *compression molding process* [4]. In a lens molding process a glass gob is heated to a temperature above the glass transition temperature and is pressed between two mold halves having the required aspheric profile. The formed lens is then either cooled naturally or by forced convection to a room temperature resulting in its final geometry. If this entire process is designed correctly, it can be easily adopted for high volume production of precision aspherical glass lenses. The flowchart in Figure 1 shows the use of a numerical simulation tool to produce the final product without the conventional iterative mold design.

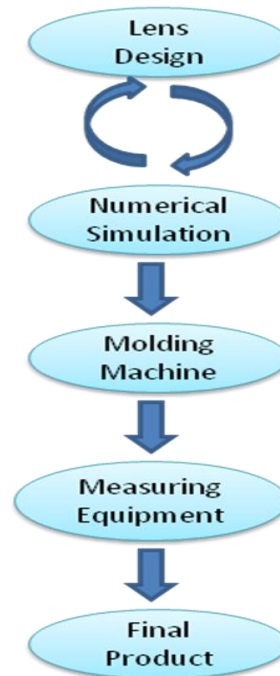

Fig 1: Production flow of aspherical lenses using a numerical simulation tool

¹ Research Assistant, Mechanical and Aerospace Engineering Dept., University of Florida, Email: shrimad@ufl.edu

² Associate Professor, Mechanical and Aerospace Engineering Dept., University of Florida, Email: nkim@ufl.edu

³ Moore Nanotechnology Systems, LLC, Email: tomhe@nanotechs.com

Numerical simulation of the entire glass molding process is a complex process. Performing an all-in-one simulation of entire molding process would not only be computationally expensive, but would incur modeling a lot of unnecessary complex processes. In addition, all-in-one modeling prevents from understanding important aspects of each process and fails to provide physical insights of the problem at hand.

In this paper we aim to analyze each sub-process that goes into the molding process and to create a computationally simplified model using engineering judgment and assumptions that would give results accurate enough for manufacturing purposes and simple enough for use for design purpose. We analyze and segregate the vital phenomenon that affect the quality of the final optical element and treat them quantitatively.

Yi *et al.* [5] showed that it is possible to use the finite element method to predict the glass molding process by using commercial software. However, there is no commercial software available customized for simulating multi-step molding processes. A more sophisticated model is required to accurately predict the manufacturing of aspheric lenses by molding and a simplified model is desired for computational expense.

Hence, in this paper we aim to

1. understand the physics of a compression glass molding process and create a simplified numerical model
2. develop a computational tool using finite elements to simulate the glass molding process for the above model

Using the above tool, one would be able to predict the final geometry of the glass after the compression molding.

From the predicted geometry of the glass, the reverse engineering of the molding process can be performed to determine the initial conditions such as, the mold profile, operating temperature, and other process parameters that would result in the desired profile of an optical element. This would be achieved by executing the tool through an optimization routine to produce the desired profile of element by treating the above quantities as design variables and minimizing the error between the desired and the resulting geometries.

The following section explains the glass molding process. Then the physics-based model for glass molding process is proposed, followed by the finite element model of the simulation of the process. Optimization to predict the mold geometry and results are discussed towards the end.

MOLDING PROCESS OF GLASS OPTICS

Technology to produce glass optics via molding currently exists commercially, but it is not widely used. We believe the major difficulties encountered are quantifying and

analyzing each process numerically that occur in the molding process and predicting the final shape of the glass element after molding. Another difficulty is to produce molds which will result in geometrically correct lens after the compression and cooling processes. The reason for this is that, during the heating and cooling process, the dimensions of both the mold cavity and glass change due to thermal effects. Residual stresses exist during the cooling process due to the phenomena of structural relaxation which further affects the geometry of the molded glass. In addition, glass is an elastic solid at room temperature, but the primary deformation of glass occurs at high temperature (550 to 700 °C) where glass behaves as a viscoelastic material and hence the material properties change at the molding temperature.

Due to the above challenges, a mold cavity that is geometrically perfect at room temperature will not produce a geometrically correct element. Predicting the geometry of molded optics from the knowledge of mold geometry is difficult. As a result, the process of creating molds is inherently iterative. Figure 2 outlines the basic steps in a compression glass molding process:

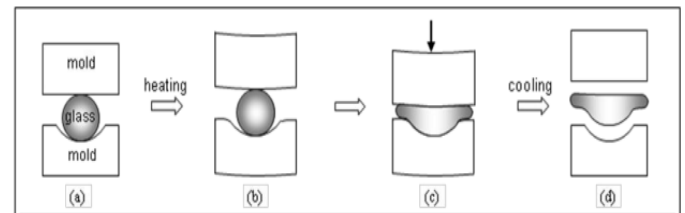

Fig 2: Glass Molding Process

- a. Initial shape of the glass and the molds at room temperature
- b. Heating process: Both glass and molds are deformed due to thermal expansion
- c. Compression process: Glass is pressed on thermally deformed mold surfaces
- d. Cooling process: Molds recover their original shapes, but final geometry of glass is different from that of molds due to thermal contraction and residual stress

DETAILED STEPS IN A GLASS MOLDING PROCESS

The typical glass molding process can be conducted in the following steps [9]:

1. Heating: Heating is the first step in the glass compression process. During this process, the molds and the glass gob are heated above the glass transition temperature. During the heating process the system is continuously purged with Nitrogen to prevent oxidation on the molds. The molds are heated to the commanded temperature by an induction heating system around the molds
2. Soaking: Soaking is necessary to achieve the steady state of constant temperature between the molds and the glass. The controller maintains the com-

manded temperature for the duration of soaking cycle time. On large sized molds and glasses, the soaking times can be of the order of few minutes to ensure uniform temperature

3. Pressing: The pressing process commences at the end of soaking cycle. Maintaining the temperature constant, the upper mold is pressed uniformly to deform the glass according to the mold profile
4. Gradual cooling: The temperature of the glass and the molds are reduced gradually till the annealing temperature of glass. The gradual cooling is done by injecting heat continuously to maintain the rate of cooling and using Nitrogen gas to cool. If needed force can be applied in this cycle
5. Steep cooling: Once the glass annealing temperature has been attained, the glass and the molds are cooled to room temperature using a high flow of Nitrogen gas. After this cycle has been completed, the glass is unloaded from the molds and a new gob loaded

Figures 3 and 4 show the glass molding apparatus along with induction heating/cooling system.

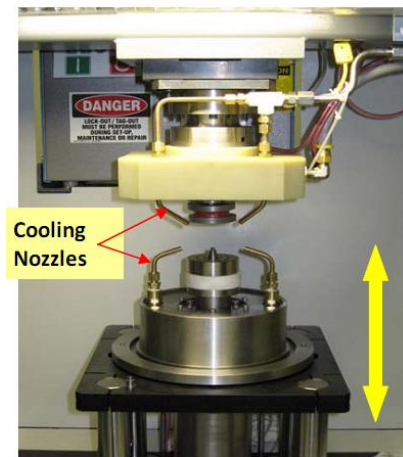

Fig 3: Molding Setup

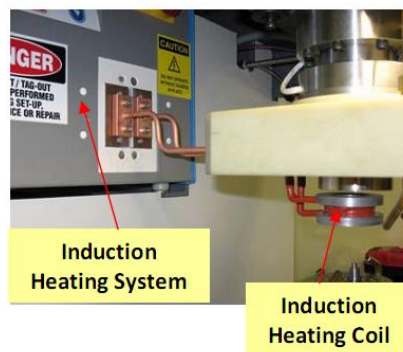

Fig 4: The Induction Heating System

The graph in Figure 5 outlines the temperature profile for the glass pressing cycle. The uniform force for pressing is applied in the pressing cycle which occurs at time T_3

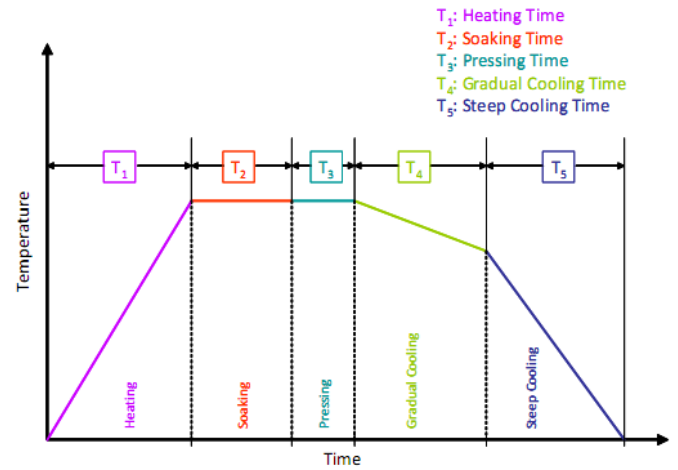

Fig 5: Glass Pressing Cycle

PHYSICS-BASED MODEL FOR THE GLASS PRESSING PROCESS

The following explains the assumptions and the physical model developed for simulating the glass pressing process.

The WC molds are highly inert and have high structural stiffness. Hence they are assumed to be rigid bodies when compared to the stiffness of the glass near its glass transition temperature. However, the molds expand and contract linearly in accordance with their thermal expansion coefficient during the heating/cooling cycle.

Glass is assumed to be linearly elastic until it attains the glass transition temperature i.e. during the heating process. Hence glass is also assumed to expand and contract linearly during the heating/cooling process. After the soaking process, during the pressing cycle, glass behaves as a non-Newtonian viscous fluid and hence is assumed to behave as a viscoelastic material.

Due to soaking, we assume the system to have achieved steady state, which means the glass and the molds are at the same temperature during the pressing process.

The gradual and steep cooling is modeled as linear thermal analysis. Since the molds and glass are assumed elastic during that phase, the rate of cooling does not affect the analysis significantly. The residual stresses that are present at the end of steep cooling cycle contribute to the residual stresses at the end. The viscoelastic stresses would have vanished due to the gradual cooling.

FINITE ELEMENT MODEL

The following described the finite element model for the simulation of the glass molding process.

Taking advantage of the symmetrical shapes of aspheric glass lenses and the molds along their axis of revolution, the molding process is modeled as a 2D axisymmetric analysis. For heating/cooling process, a linear thermoelastic model is used. For compression process, nonli-

near, large deformation, viscoelastic, four-node quadrilateral element is implemented. The nonlinear system of equations is solved iteratively using Newton-Raphson method.

THERMAL ANALYSIS

Linear thermal analysis is implemented to quantify the deformation of the molds and glass during the heating and cooling process. For glass, the thermal expansion of its radius is calculated analytically by multiplying the initial radius with its thermal expansion coefficient. For molds, linear thermoelastic analysis is performed using finite elements. Figure 6 shows the meshing of the lower axisymmetric mold. The top profile is the aspheric profile. From the thermal analyses, the surfaces of the molds are extracted and modeled as rigid surfaces for the next cycle; i.e., the pressing analysis.

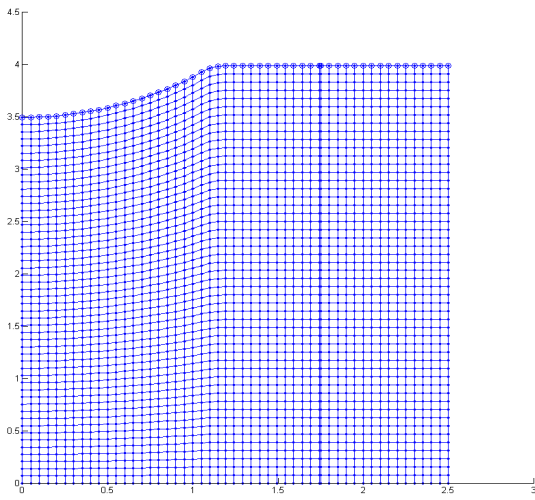

Fig 6: Meshing of the Lower Aspheric Mold

The profile of the deformed surface is obtained by adding the nodal displacements of the above analysis to the original coordinates of the mold as

$$(\underline{P}_{new}) = (\underline{d}_{thermal}) + (\underline{P}_{old}) \quad (1)$$

where (\underline{P}_{new}) is the new profile of the mold surface, $(\underline{d}_{thermal})$ is the vector of displacements from the thermal analysis, and (\underline{P}_{old}) is the initial profile of the mold. The thermally expanded profile is used for the pressing analysis.

Figure 7 shows the original and the deformed geometry of the surface of the mold after thermal analysis. The temperature of the WC mold has been raised by 550°C. The upper mold surface is the thermally expanded mold surface. The expansion has been magnified by a factor of 50 to contrast the expansion against the original shape. The units are in millimeters.

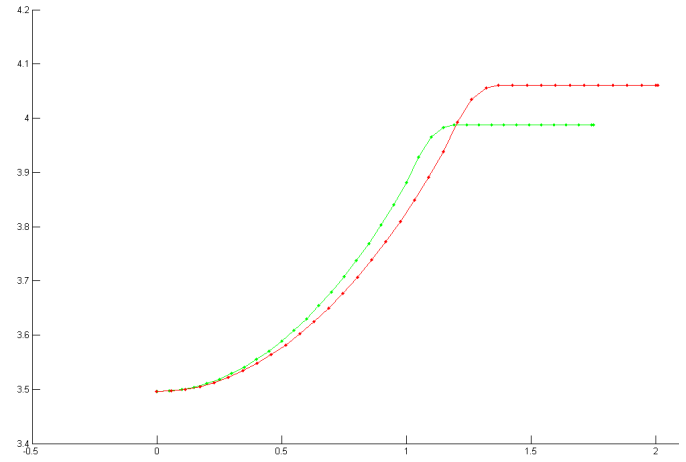

Fig 7: Expansion of Mold Surface during Heating Cycle

VISCOELASTIC MATERIAL MODELING FOR GLASS

Since the strains incurred are quite large, small strain viscoelasticity coupled with large deformation effects is adopted.

Glass near its transition temperature can be considered to be an incompressible viscous non-Newtonian fluid [14]. Hence we assume the following properties of glass during the compression phase:

1. Glass is incompressible near its transition temperature; which implies the Poisson's ratio to be nearly 0.5
2. The relaxation occurs only in the shear modulus and that there is no relaxation in the bulk modulus
3. As a result of above, there is relaxation in the deviatoric component of stress, and no relaxation in volumetric component of stress due to the constant bulk modulus

Generalized Maxwell model [13] is used to formulate the viscoelastic material behavior. Figure 8 shows the modeling of a viscoelastic material using a generalized Maxwell model. The Maxwell model is implemented only in the shear modulus and hence there is relaxation only in deviatoric stress. The Maxwell parameters are determined by experimental compression tests which will be addressed later.

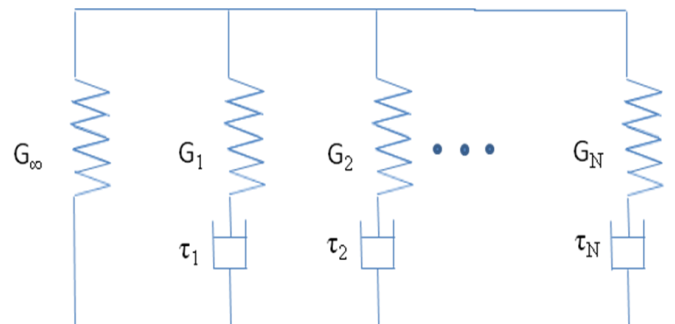

Fig 8: Generalized Maxwell Model

In Figure 8, G_∞ is the elastic shear modulus at infinite time, N is the number of Maxwell elements to be modeled, $G_1 \dots G_N$ is shear modulus of each Maxwell element, and $\tau_1 \dots \tau_N$ is the time constant of each Maxwell element.

In the Maxwell model, the relaxation of the shear modulus can be expressed by the following equation [13]:

$$G(t) = G_\infty + \sum_{i=1}^N G_i \exp(-t / \tau_i) \quad (2)$$

At instantaneous time; i.e., $t \approx 0$, the effect of all dashpots is negligible and the instantaneous shear modulus can be obtained as

$$G(0) = G_0 = G_\infty + \sum_{i=1}^N G_i \quad (3)$$

On the other hand, at infinite time, $t \approx \infty$, the effect of all springs vanishes and the shear modulus at infinite time becomes

$$G(\infty) = G_\infty \quad (4)$$

Due to the presence of the dashpots, the response is time dependent. Since glass is assumed to as a non-Newtonian fluid near the transition temperature, it is incompressible. Hence the viscoelastic relaxation is considered only in the shear modulus. There is no relaxation in bulk modulus and is constant during the analysis.

Due to the inclusion of the effects of large deformation, the constitutive equations are formulated in terms of the rotated stress $R^T \sigma R$, where R is the rotation arising from the polar decomposition of the deformation gradient F . Let $R^T \sigma R = \Sigma + p \mathbf{1}$ where Σ is the deviatoric part and p is the pressure part. The constitutive relation for a viscoelastic response taking the rotation into account is given as [10, 11]

$$\Sigma = \int_0^t 2G_\infty + \sum_{i=1}^n G_i \exp\left(-\frac{t-\tau}{\tau_i}\right) (R^T dR) d\tau \quad (5)$$

where t is the pseudo or the past time, G_∞ is the elastic shear modulus, n is the number of Maxwell elements, G_i is the shear modulus of i^{th} Maxwell element, τ_i is the relaxation time of i^{th} Maxwell element, and d is deviatoric component of R .

Assuming the stress at n^{th} load step is known, we obtain the recursive formula for calculating the current stress by the midpoint integration of the above integral from 0 to t_{n+1} resulting in:

$$\begin{aligned} (S_i)_{n+1} = & \exp\left(-\frac{\Delta t}{\tau_i}\right) \Delta R (S_i)_n \Delta R^T \\ & + 2 \exp\left(-\frac{\Delta t}{2\tau_i}\right) G_i \Delta R_{1/2} (\Delta \varepsilon_{n+1/2}) \Delta R_{1/2}^T \end{aligned} \quad (6)$$

where, $\Delta R = R_{n+1} R_n^T$, $\Delta R_{1/2} = R_{n+1} R_{n+1/2}^T$, $\Delta \varepsilon_{n+1/2}$ is the strain tensor at " $n+1/2$ " and $\Delta \varepsilon_{n+1/2}$ is the deviatoric component of $\Delta \varepsilon_{n+1/2}$ strain tensor.

The above stress is the viscoelastic stress which will relax with increasing time due to the presence of the decaying exponential term.

The elastic shear stress arising from the instantaneous modulus is obtained by integration procedure similar to above:

$$(S_\infty)_{n+1} = \Delta R (S_\infty)_n \Delta R^T + 4G_\infty \Delta R_{1/2} \Delta \varepsilon_{n+1/2} \Delta R_{1/2}^T \quad (7)$$

Since there is no relaxation in bulk modulus, the pressure response is given by:

$$(P_1)_{n+1} = (P_1)_n + 2K \Delta \varepsilon_{V_{n+1/2}} \mathbf{1} \quad (8)$$

where K is the bulk modulus, $\Delta \varepsilon_{V_{n+1/2}}$ is the volumetric strain, and $\mathbf{1}$ is second order identity tensor.

By combining Eqs. (6) – (8), the total Cauchy stress at load step " $n+1$ " is given as:

$$\sigma_{n+1} = (P_1)_{n+1} \mathbf{1} + (S_\infty)_{n+1} + \sum_{i=1}^N (S_i)_{n+1} \quad (9)$$

Hence we can see that the viscous stresses would relax with passing time, but the stresses due to the pressure and the instantaneous modulus of elasticity would be present. They would result in residual stresses.

BOUNDARY CONDITIONS

The finite element model is developed such that the glass and the center of the mold surface have initial contact on the axis of symmetry. Hence the common node at the origin (common to the flexible and rigid surface) is fixed to prevent any rigid body displacement.

The lower rigid nodes are fixed in all degrees of freedom and the upper mold surface is specified with the displacement necessary for compression.

For the thermal analysis, the center of the aspheric profile along the symmetry axis is fixed to prevent rigid body rotation. Fixing this node also preserve the origin of the model even though the mold surface changes its profile.

IDENTIFICATION OF MATERIAL PROPERTIES

Cylindrical compression test is performed to identify the Maxwell parameters of the glass. The cylindrical compression test is performed by imposing an instantaneous strain on a cylindrical glass sample and noting the decay of the stress with passing time, whilst maintaining a constant strain. Since the compression is comparatively small, small strain viscoelastic constitutive equation is used for fitting the parameters. The small strain viscoelastic stress response is given by [11]:

$$\sigma = \int_0^t 2G(t-\tau) \frac{de}{d\tau} d\tau + K \varepsilon_V \mathbf{1} \quad (10)$$

where,

$$G(t - \tau) = G_{\infty} + \sum_{i=1}^N G_i \exp\left(\frac{-t + \tau}{\tau_i}\right) \quad (11)$$

and e is the deviatoric strain tensor, τ is the past time or pseudo time, K is the bulk modulus, and ε_v is the volumetric strain.

The first stress component is the shear stress, which has the relaxation function and the second component is the volumetric stress with no relaxation.

In the compression then, the instantaneous strain is applied linearly and then the strain is held constant while noting the decay of stress. Hence the above integral is integrated analytically to obtain analytical expressions for the stress. Then the analytical stress expressions are fitted to the experimental data to determine the Maxwell parameters which minimize the error [12].

CONTACT ANALYSIS

Contact between glass and molds are modeled using slave-master concept [15]. In this model, a node on the surface of the glass model cannot penetrate into linear segments of model surface. Since the elastic moduli between glass and molds are significantly different, the mold surface is assumed to be rigid body. Penalty method is used to impose the impenetrability constraint.

RESULTS AND FUTURE WORK

Figure 9 shows the final geometry of a compressed spherical N-BK7 glass with an aspheric lower mold and flat upper mold. The initial glass gob is spherical in shape with diameter of 2.0mm and is compressed by 1.2mm at a uniform rate. The molding temperature is 550°C and the ambient temperature is 25°C. The results are verified using commercial software ANSYS. In the future, the simulation results will be validated using experiments.

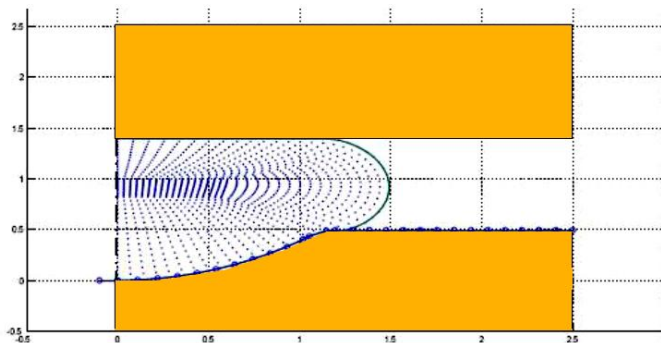

Fig 9: Final Geometry of Glass after Molding Process

Figure 10 shows the profiles of the final geometry of the glass and the initial shape of the mold profile, which is the desired glass profile at the end of the molding process. We can clearly see the significant difference in the profile due to the various processes that go in the glass molding process. The difference of the final glass profile is scaled by 20% to bring out the visual contrast

between the profiles. The longer profile is that of the final deformed glass, and the other profile is the initial mold geometry. It is desired that both the profiles are identical, but the same is not achieved.

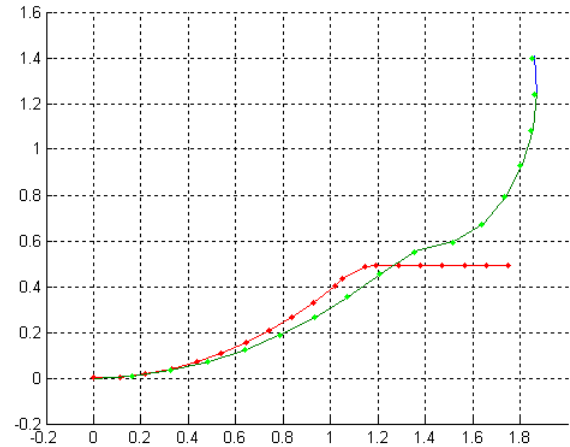

Fig 10: Difference between the final Glass and Initial Mold Profile

The developed simulation tool is computationally cheap and can execute the simulation much quicker than a complex commercial software analysis. Hence the tool can be optimized to predict the initial mold geometry and the process parameters required in order to obtain the desired glass profile.

CONCLUSIONS AND FUTURE PLANS

In this paper, instead of a complicate all-in-one glass molding analysis, a simplified multi-step analysis process based on engineering analysis is presented. A physical model and a computational tool are successfully developed to predict each sub-process in a glass molding process quantitatively. The analyses of the sub processes are integrated to result in a tool which can predict the final geometry of glass the end of the compression molding process. With the help of this tool, the final geometry of the glass can be predicted after the molding process.

Using the final geometry of the lens that is obtained above, the mold geometry that would result in a given desired optical geometry can be obtained minimizing the error between the generated shape of the lens and the desired shape. This is achieved by setting up an optimization routine that would iteratively find the mold geometry and the process parameters required to produce an optical element of desired profile.

ACKNOWLEDGEMENT

This research was funded by NSF and Moore Nanotechnology Systems, LLC. We are thankful for their support.

REFERENCES

- 1 A. Y. Yi. "Optical Fabrication" pp. 1945-59 in Encyclopedia of Applied Physics, Edited by P. K, Mailick. Marcel-Decker Publishers, New York, 2003
- 2 H. H. Brown (ed.), Fabrication Methods for Precision Optics. John Wiley & Sons, Inc. New York. 1993
- 3 Jain, Allen Y.Yi, "Numerical Modeling of Viscoelastic Stress Relaxation During Glass Lens Forming Process", J. Am. Ceram. Soc., 88[3] 530-535 (2005)
- 4 R. O. Maschmeyer. C. A. Andrysick. T. W. Geyer, H. E. Meissner. C. Jarker, and L. M. Sanlord. "Precision Molded Glass Optics" Appl. Opt. 22,2413-5(1983)
- 5 Y. Yi, A. Jain "Combined Molding of Asphere Glass Lenses—A combined Experimental and Numerical analysis", J. Am. Ceram. Soc. 88 [3] 579-586 (2005)
- 6 S. Rekhson, "Viscoelasticity of Glass;" pp. 1–115 in Glass Science and Technology, Edited by D. R. Uhlmann, and N. J. Kreidl. Academic Press Inc., Florida,USA, 1986
- 7 Schott Glass Inc., "Products and Applications," <http://www.schott.de>
- 8 R. Christensen, "Theory of Viscoelasticity"
- 9 F. Klocke *et al.*, "Finite element analysis of glass molding", Fraunhofer Institute of Production Technology, Aachen, Germany, 2007
- 10 ANSYS Theory Manual, "Materials with Geometric Nonlinearities"
- 11 J. C. Simo, T.R. Hughes, "Computational Inelasticity"
- 12 T. Chen, "Determining Prony Series for a Viscoelastic Material from Time Varying Data", US Army Research Center, Langley Research Center, VA, NASA / TM-2000-210123
- 13 N. Phan-Tein, "Understanding Viscoelasticity: Basics of Rheology"
- 14 D. R. Uhlmann and N. J. Kreidl, Glass Science and Technology, Volume 3, "Viscosity and Relaxation"
- 15 N. H. Kim, K. K. Choi, J. S. Chen, and Y. H. Park, Meshless shape design sensitivity analysis and optimization for contact problem with friction, Computational Mechanics, Vol. 25, No. 2/3, pp. 157-168, 2000